

ISOMAG

The friendly magmeter

MS 3770

INSERTION FLOW METER



INSERTION SENSOR FOR MOUNTING IN A NON PRESSURIZED LINE

Warranty conditions are available on this website:
www.isomag.eu only in English version

ISOIL 
INDUSTRIA
The solutions that count

TECHNICAL DATA

Body material	<input type="checkbox"/> Stainless steel AISI 304 <input type="checkbox"/> Stainless steel AISI 316 (Optional)
Size for pipe line Ø	<input type="checkbox"/> Size 1 Ø ≤ 500mm <input type="checkbox"/> Size 2 Ø ≤ 1000mm <input type="checkbox"/> Size 3 Ø ≤ 2000mm <input type="checkbox"/> Other on request
Nominal pressure	<input type="checkbox"/> PN 1600 kPa <input type="checkbox"/> Others on request
Process connection	<input type="checkbox"/> 1" Threaded end <input type="checkbox"/> Others on request
Connection material	<input type="checkbox"/> Stainless steel AISI 304
Liquid temperature	<input type="checkbox"/> 0°C ÷ 100°C compact version <input type="checkbox"/> 0°C ÷ 130°C separate version
Lining material/gasket	<input type="checkbox"/> PTFE/FPM
Electrode material	<input type="checkbox"/> Stainless steel AISI 316L <input type="checkbox"/> Other on request
Version – protection rating	<input type="checkbox"/> Compact version – IP 67 <input type="checkbox"/> Separate version (max 20m) – IP 68 <input type="checkbox"/> Separate version (max 500 m), with preamplifier – IP 67 (OPT. IP 68)
Accuracy	<input type="checkbox"/> See table below

OVERALL DIMENSIONS

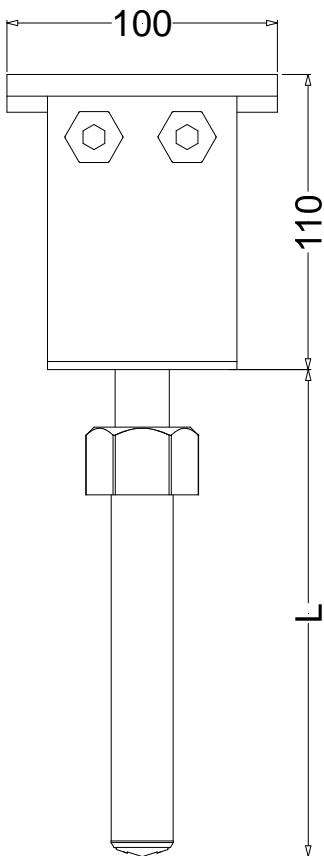
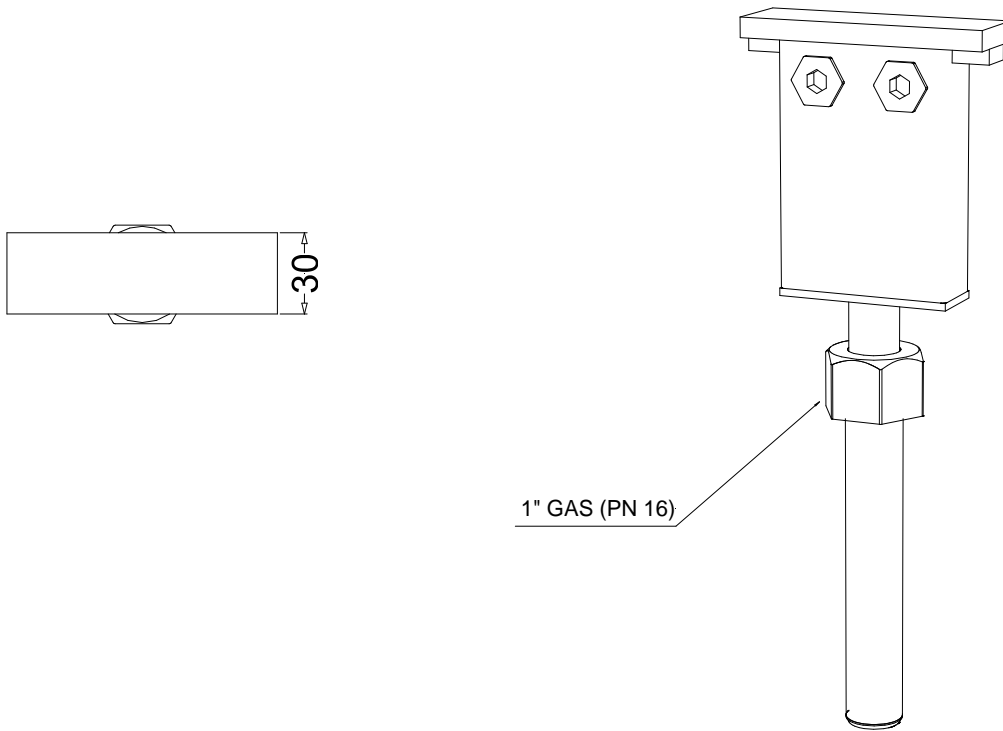

1" GAS (PN 16)

SIZE	DN RANGE	L
SIZE 1	FROM DN 80 UP TO DN 500	176
SIZE 2	FROM DN 80 UP TO DN 1000	244
SIZE 3	FROM DN 80 UP TO DN 2000	462

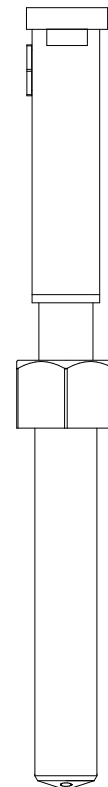

INSTALLATION

Fig. 1

Cut the Ø 1" jacket as in picture 1.
(check also Fig. 6)
ATTENTION: consider the necessary over-metal for the welding operation

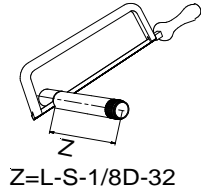

Z=L-S-1/8D-32

Fig. 2

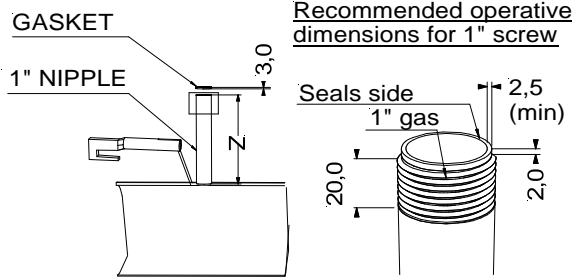

weld the nipple to the pipe line

Fig. 3

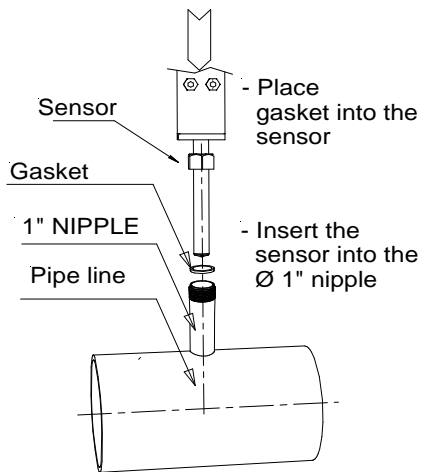

Fig. 4

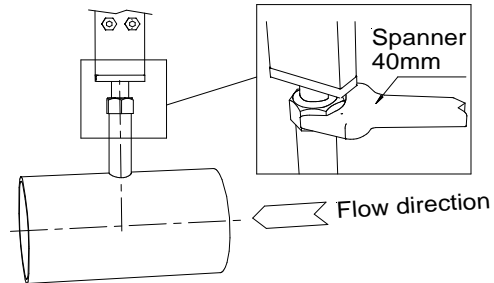

Fig. 5

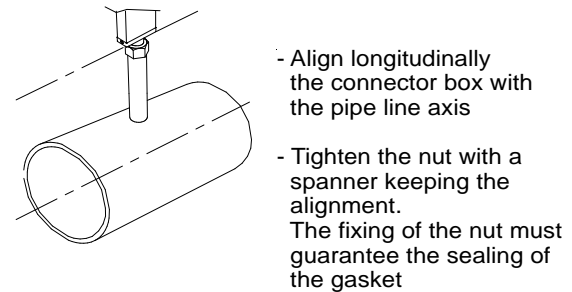
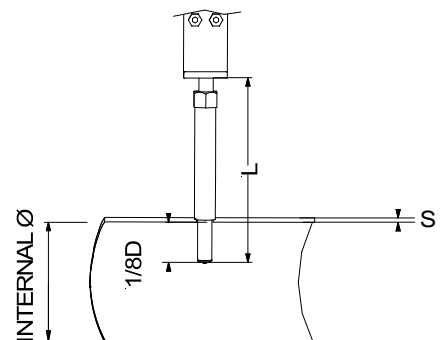

Fig. 6

SIZE	DN RANGE	L
SIZE 1	DN 80 UP TO DN 500	176
SIZE 2	DN 80 UP TO DN 1000	244
SIZE 3	DN 80 UP TO DN 2000	462

Sensor installed



INSTALLATION RECOMMENDATIONS

In vertical installations an ascending flow is preferable. For vertical installations with descending flow direction contact the manufacturer

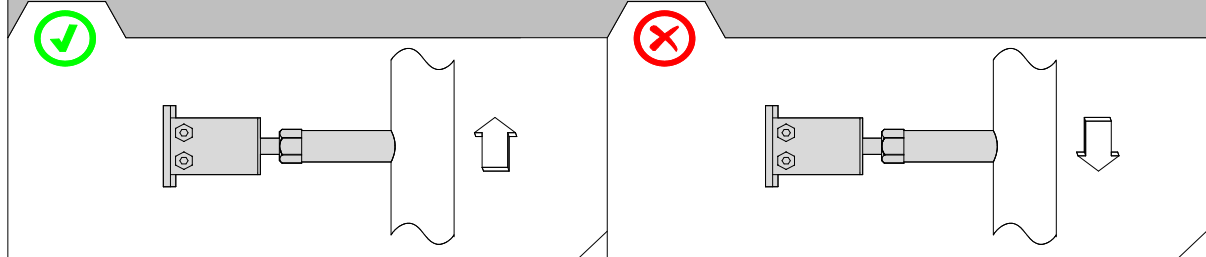

Avoid a partially empty pipe, during operation the pipe must be either completely full of liquid or completely empty

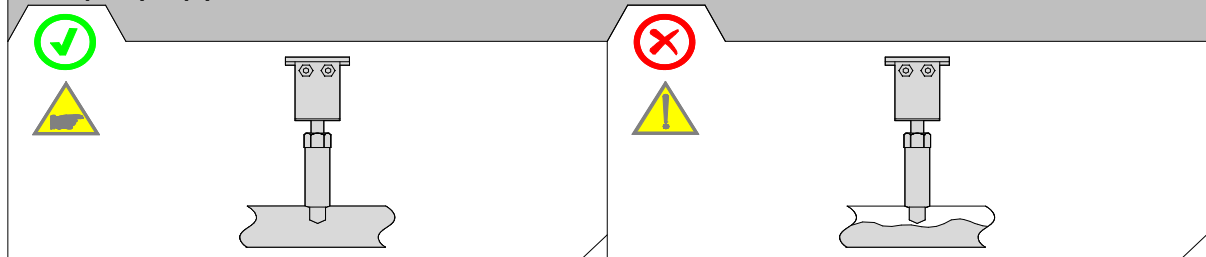

Install the sensor away from bends and hydraulic accessories

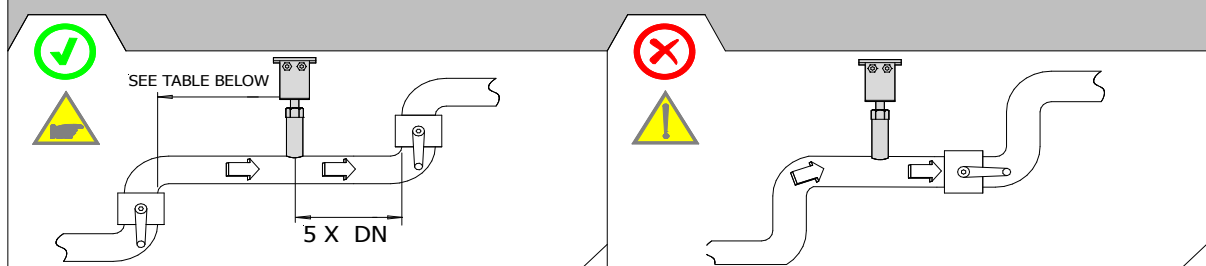

Min upstream straight length expressed in multiples of conduit diameter.

Disturbance upstream from the measuring point	Valid for a measurement at the point of mean axial velocity	Valid for a measurement on the axis of the pipe
90° elbow or a t-bend	50	25
Several 90° coplanar bends	50	25
Several 90° non- coplanar bends	80	50
Total angle convergent 18 to 36°	30	10
Total angle divergent 14 to 28°	55	25
Fully opened butterfly valve	45	25
Fully opened plug valve	30	15

NOTE : According to data from UNI1072700_1998

SENSOR GROUNDING

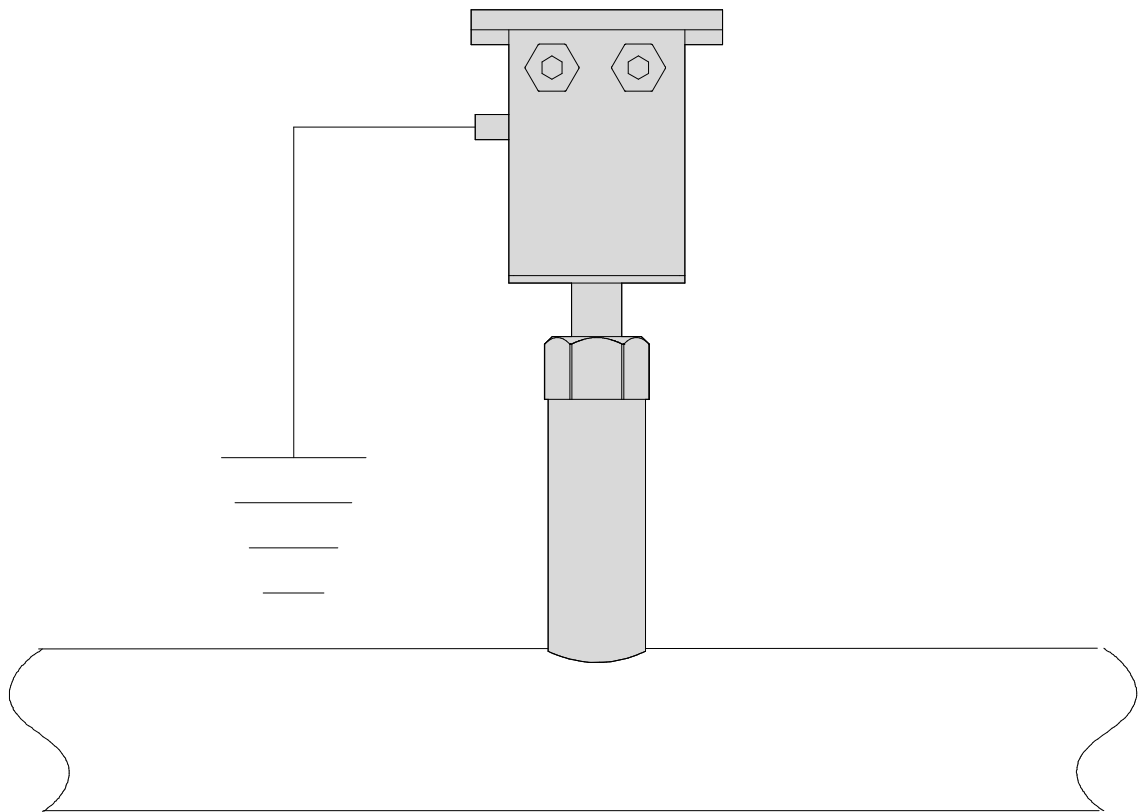

**For the correct operation of the meter the sensor and liquid must be equipotential. ALWAYS connect sensor and converter to the ground.
For grounding with a cathodic protection pipe, please contact the manufacturer.**

SEPARATE VERSION

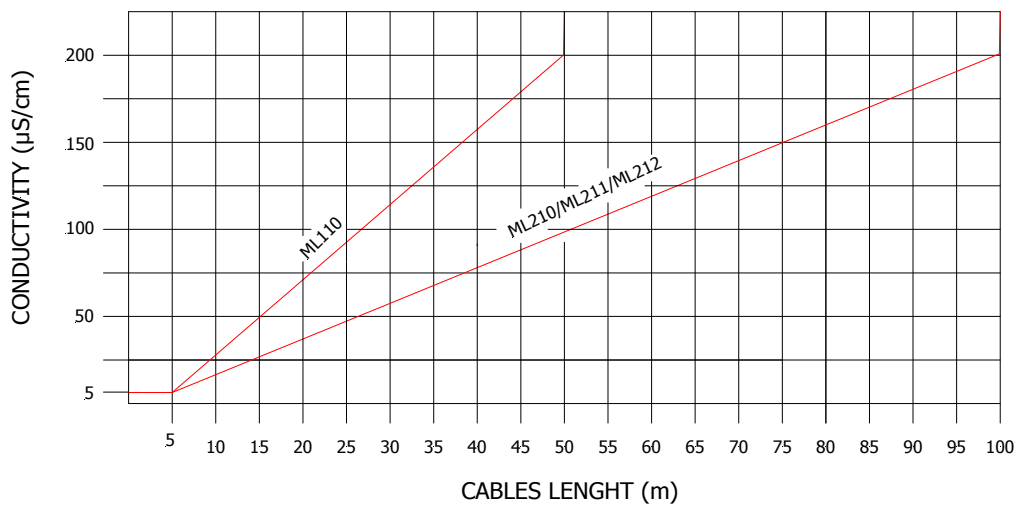
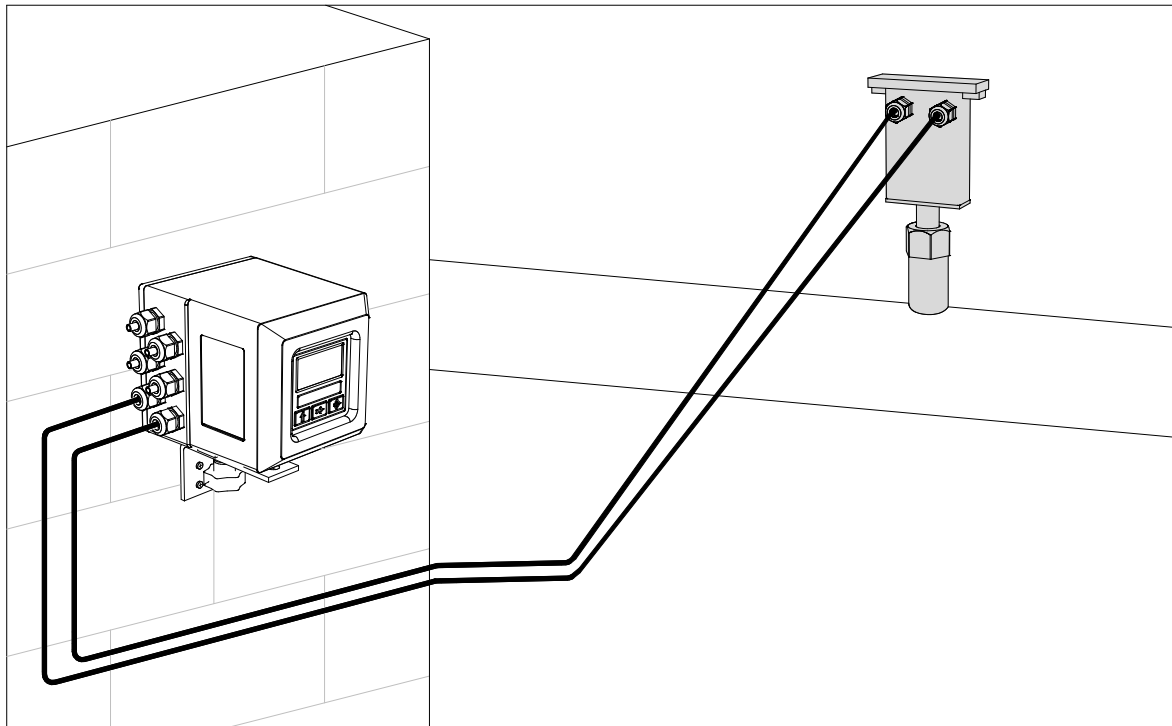
**Notes:**

- It is recommended to install the connection cables away from, or protect against sources of electromagnetic noise.
- The minimum conductivity of the liquid medium to ensure correct functionality of the empty pipe detection is $20 \mu\text{S/cm}$

ACCURACY TABLE

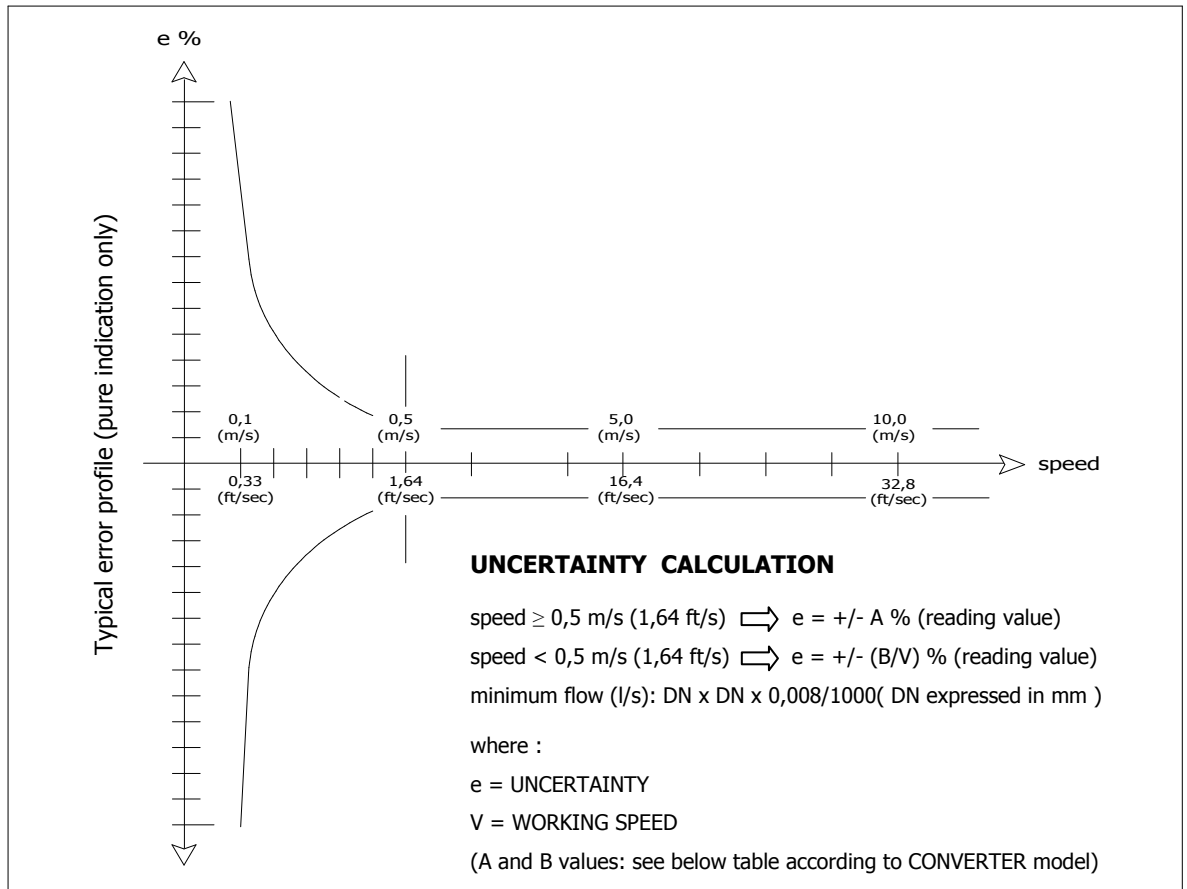

ALL CONVERTERS

A	B (m/s)	B (ft/s)
2	1	3,28

Reference conditions :

- Constant flow rate during the test
- Pressure: >30 Kpa
- Flow condition : fully developed flow profile
- Zero stability +/- 0,005 %

HOW TO ORDER

MS 3770	DN range pipeline
1	suitable for diameter < / = 500 mm.
2	suitable for diameter < / = 1000 mm.
3	suitable for diameter < / = 2000 mm.
9	suitable for diameter : to be specified
Sensor and electrodes material / lining	
A	Sensor material AISI304, PTFE lining, electrodes in AISI316 (gasket in FPM) , junction box in AISI 304
Z	Sensor material: to be specified
Accessory for mounting in pressurised pipe line	
1	1" male threaded connection
0	Special connection: to be specified
Execution - Protection rate	
A	Compact version, IP67 protection rate, liquid maximum temperature 100 °C
B	Separate version "C", maximum length see table, liquid maximum temperature 130 °C, protection rate IP68
C	Separate version "L" (in Carbon Steel), with preamplifier (maximum length 500 m), liquid maximum temperature 100 °C, protection rate IP67
D	Separate version "L" (in AISI304), with preamplifier (maximum length 500 m.), liquid maximum temperature 100 °C, protection rate IP67
E	Version with length and position of the neck of the Sensor to define according draw. G006 (valid for A-B-C-D versions, add the relative COST)
F	Separate version with N° 2 connectors IP 68 suitable for C015/16 for fast cable connections (max 20 m-ADD THE COST)
G	Separate version with N° 1 connectors IP 68 suitable for C18 for fast cable connections (max 20 m-ADD THE COST)
H	Separate version, with N° 1 connectors IP 68 suitable for C014 for fast cable connections TO PREAMPLIFIER IN CARBON STEEL (DEFINE LENGHT MAX 500 m-ADD THE COST)
I	Separate version with N° 1 connectors IP 68 suitable for C014 for fast cable connections TO PREAMPLIFIER IN STAIN. STEEL (DEFINE LENGHT MAX 500 m-ADD THE COST)
M	Compact version, IP67 protection rate , with the possibility to turn the converter 90°

MS 3770 1 A 1 A **EXAMPLE OF ORDER CODE**

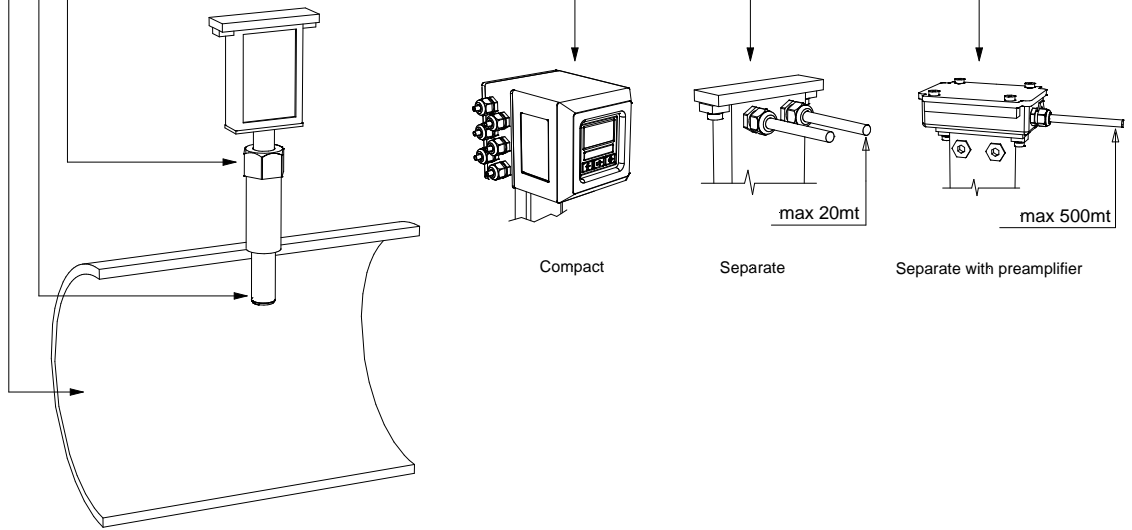

The manufacturer reserves the right to make design improvements without notice.